

E	7	6	5	4	3	2	1
D	7	6	5	4	3	2	1
C	7	6	5	4	3	2	1
B	7	6	5	4	3	2	1
A	7	6	5	4	3	2	1

Izmena Revision	NACIONALNE VLASTI/FLAG STATE AUTHORITIES	Opis Description	Datum Date	Ime Name	Datum/Date
KLASIFIKACIJSKO DRUŠTVO/CLASSIF. SOCIETY	VLASNIK/OWNER	Dopis broj/Letter No.	BIS PROJEKTI NI URED - SPLIT DIV GRUPA d.o.o.	Veza na crt./Connecting dwg.	
Odobreno od/Approved by	Ime Name	Potpis Signature	Datum Date	Zam. Docentide	Yard:
Tzradio Designed by	08.2023	Miloš Mikić	08.2023	Miloš Mikić	BRODOSPLUT DIZAJNERSTVO I INŽINJERING D.O.O.
Pripremljeno Checked by	08.2023	Miloš Mikić	08.2023	Miloš Mikić	NOV / NB 841
Odobrio Head of project	08.2023	Miloš Mikić	08.2023	Miloš Mikić	PR. / PROJECT IRI 12
Mjerilo/Scale	Naziv nacrt./Drawing title	PIPES POSITION ON PLATFORM ASSEMBLIES - GROUP 500	Listova/Pgs A + 4	List/Pg A	Ident broj/Req No

# SET 37 - 1 pcs.

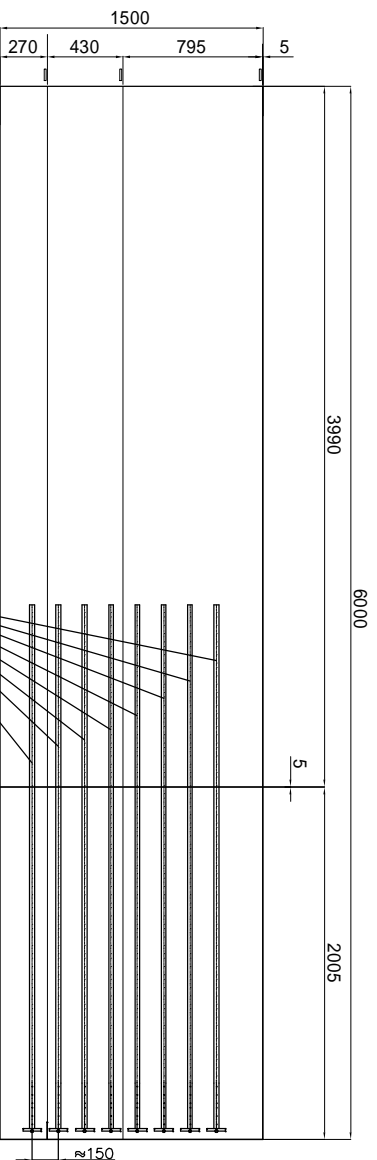

REMARKS:  
 PIPE ASSEMBLY ND20 FOR MICRO PANEL SET 37 SHOULD BE MARKED AND  
 PACKED TOGETHER WITH OTHER PIPE ASSEMBLY OF MICRO PANEL.

NOMINAL DIAMETER ND	OUTER DIAMETER Do (mm)	WALL THICKNESS (mm)	STANDARD	MATERIAL
20	26,9	2,0	EN 10216-5	2205

PIPE LENGTH L = 3000 mm; 8 PIECES  
 3000

PIPE DIAMETER ND20; MATERIAL  
 DUPLEX 2205

FLANGE EN 1092-1; type 01; pn6; RATED  
 DIAMETER ND20; MATERIAL DUPLEX 2205  
 (316L); 8 PIECES

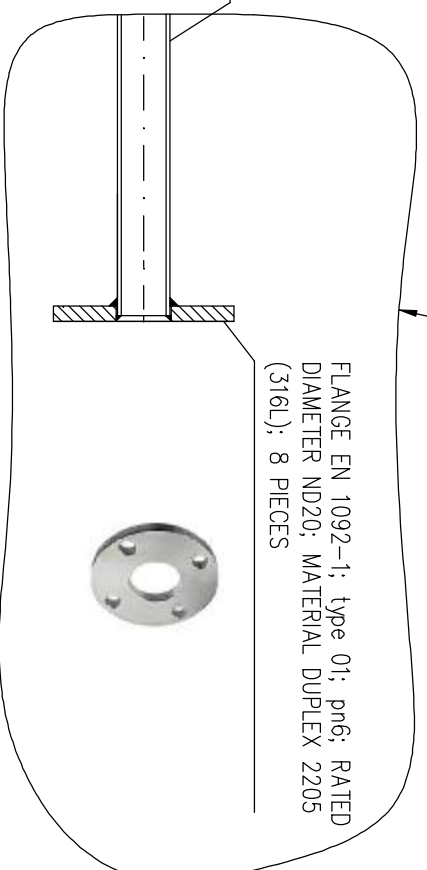

# SET 40 - 1 pcs

6000

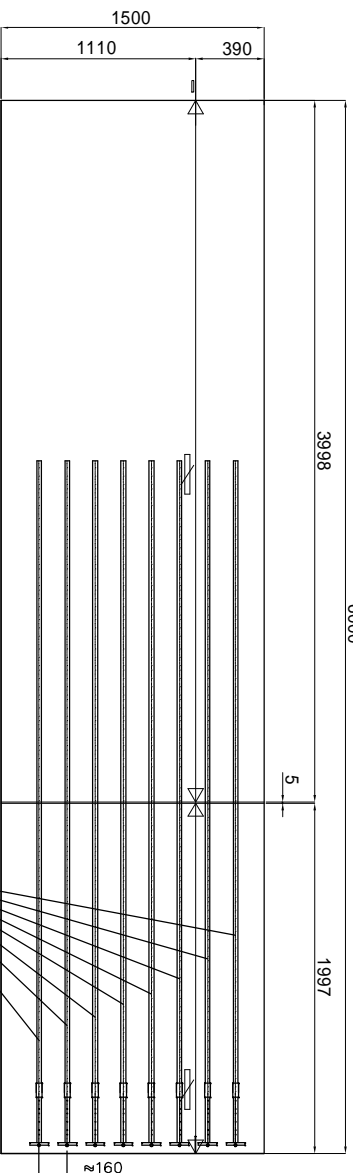

REMARKS:  
 PIPE ASSEMBLY ND20 FOR MICROPANEL SET 40 SHOULD BE MARKED AND  
 PACKED TOGETHER WITH OTHER PIPE ASSEMBLY OF MICROPANEL.

NOMINAL DIAMETER ND	OUTER DIAMETER Do (mm)	WALL THICKNESS (mm)	STANDARD	MATERIAL
20	26,9	2,0	EN 10216-5	2205
25	33,7	2,0	EN 10216-5	2205

PIPE LENGTH L = 3900 mm; 8 PIECES

3900

PIPE DIAMETER ND25; L=80mm; MATERIAL  
 DUPLEX 2205

REMARKS: DO NOT WELD ON PIPE ND20

PIPE DIAMETER ND20; MATERIAL  
 DUPLEX 2205

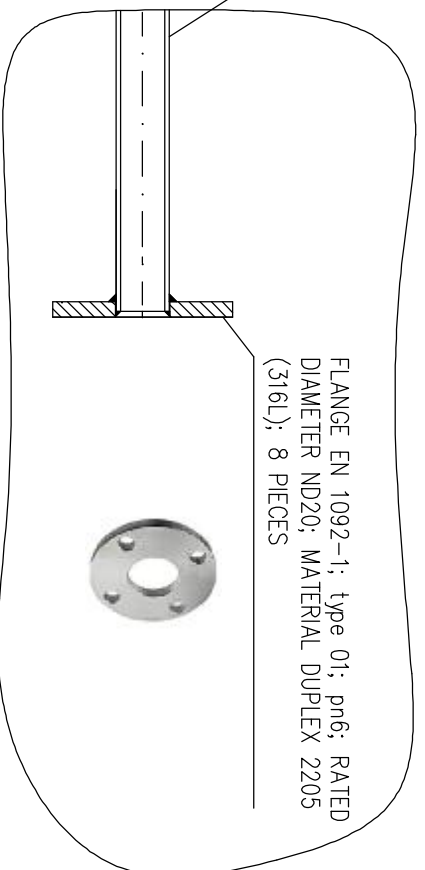

FLANGE EN 1092-1; type 01; pn6; RATED  
 DIAMETER ND20; MATERIAL DUPLEX 2205  
 (316L); 8 PIECES

# SET 41 - 1 pcs.

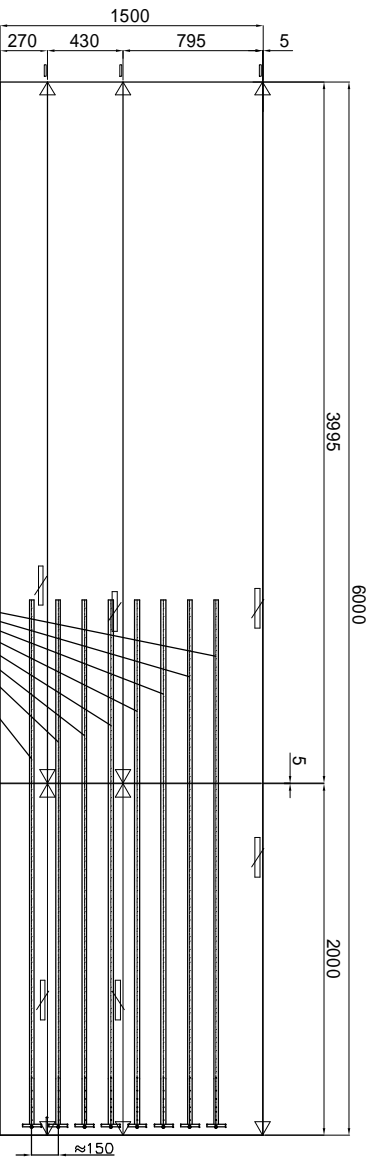

REMARKS:  
PIPE ASSEMBLY ND20 FOR MICROPANEL SET 41 SHOULD BE MARKED AND PACKED TOGETHER WITH OTHER PIPE ASSEMBLY OF MICROPANEL.

NOMINAL DIAMETER ND	OUTER DIAMETER Do (mm)	WALL THICKNESS (mm)	STANDARD	MATERIAL
20	26,9	2,0	EN 10216-5	2205

PIPE LENGTH L = 3000 mm; 8 PIECES

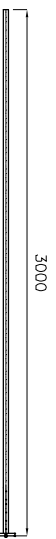

PIPE DIAMETER ND20; MATERIAL DUPLEX 2205

FLANGE EN 1092-1; type 01; pn6; RATED DIAMETER ND20; MATERIAL DUPLEX 2205 (316L)

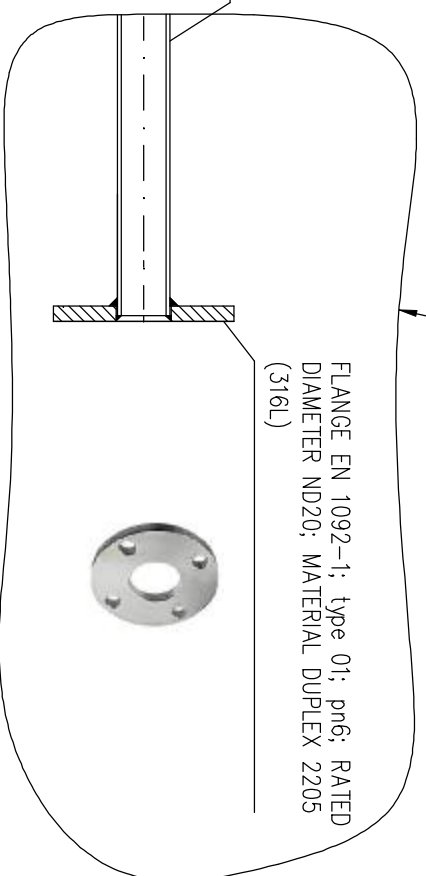

# SET 44- 1 pcs

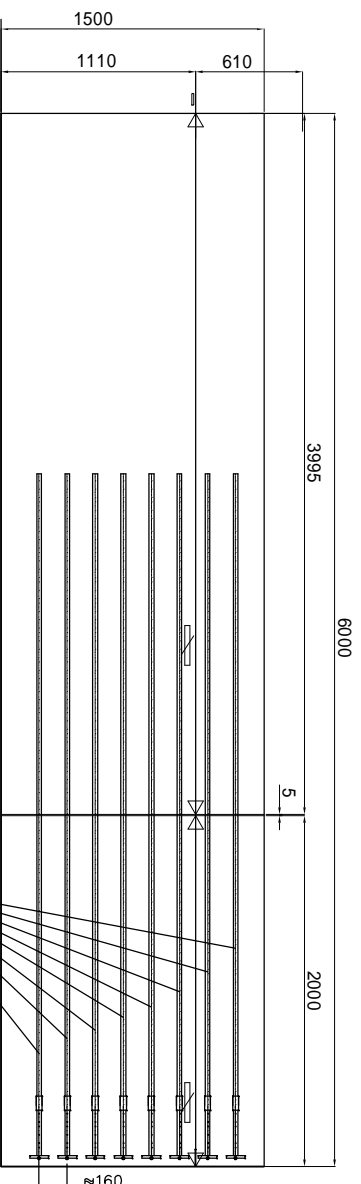

REMARKS:  
 PIPE ASSEMBLY ND20 FOR MICRO PANEL SET 44 SHOULD BE MARKED AND  
 PACKED TOGETHER WITH OTHER PIPE ASSEMBLY OF MICRO PANEL.

NOMINAL DIAMETER ND	OUTER DIAMETER Do (mm)	WALL THICKNESS (mm)	STANDARD	MATERIAL
20	26,9	2,0	EN 10216-5	2205
25	33,7	2,0	EN 10216-5	2205

PIPE LENGTH L = 3900 mm; 8 PIECES

3900

PIPE DIAMETER ND25; L=80mm; MATERIAL  
 DUPLEX 2205

REMARKS: DO NOT WELD ON PIPE ND20

PIPE DIAMETER ND20; MATERIAL  
 DUPLEX 2205

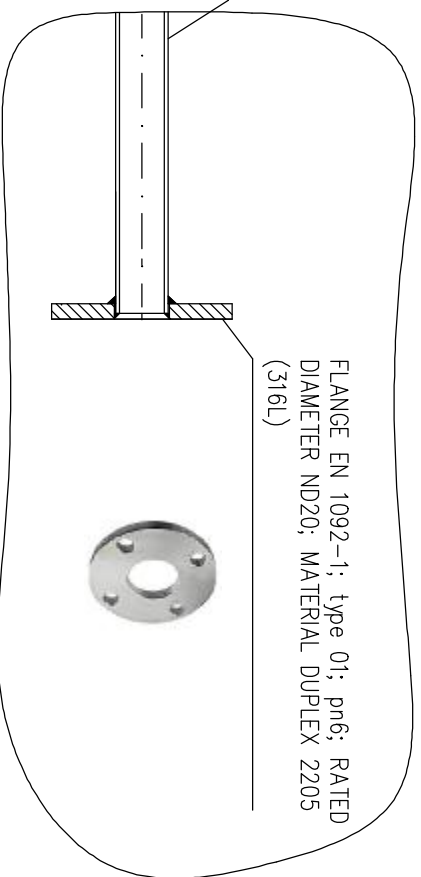

FLANGE EN 1092-1; type 01; pn6; RATED  
 DIAMETER ND20; MATERIAL DUPLEX 2205  
 (316L)

