



**COMPANY CONFIDENTIAL**  
 THIS DRAWING AND ALL INFORMATION CONTAINED HEREIN IS THE PROPERTY OF "BRODOSPLIT d.d."  
 AND IS NOT TO BE USED EXCEPT AS EXPRESSLY AUTHORIZED IN WRITING BY SAID COMPANY

Izmjena Revision		Opis Description		Datum Date	Ime Name
NACIONALNE VLASTI/FLAG STATE AUTHORITIES					
KLASIFIKACIJSKO DRUŠTVO/CLASSIF. SOCIETY					
VLASNIK/OWNER					
Odobreno od/Approved by		Dopis broj/Letter No.		Datum/Date	
Datum Date	Ime Name	Potpis Signature	Designer:	Veza nacrt/Connecting dwg.	
	Zeljko Carev		BIS PROJEKTI URED - SPLIT		
Izradio Designed by	Mirna Sisković		DIV GRUPA d.o.o.		
Pregledao Checked by	Mirna Sisković		Yard:		
Odobrio Head of Dept.	Mirna Sisković				
Mjerilo/Scale	Naziv nacrt/Drawing title				
	PRSTENOV I ZA PODMORNICU		NOV / NB		
	RINGS FOR SUBMARINE		548		
	PR. / PROJECT	Klasif. broj/Dwg.No			
	02-201-307	02-201-307			
	Listova/Pgs	List/Pg	Ident broj/Reg. No		
	5	1/5	332819		

# AFT HULL VIEWPORT FLANGE

BIS PROJEKTI NI URED - SPLIT  
DIV GRUPA d.o.o.

POS. 211.001-015 1 PCS

MATERIAL: ASTM A350 LF2

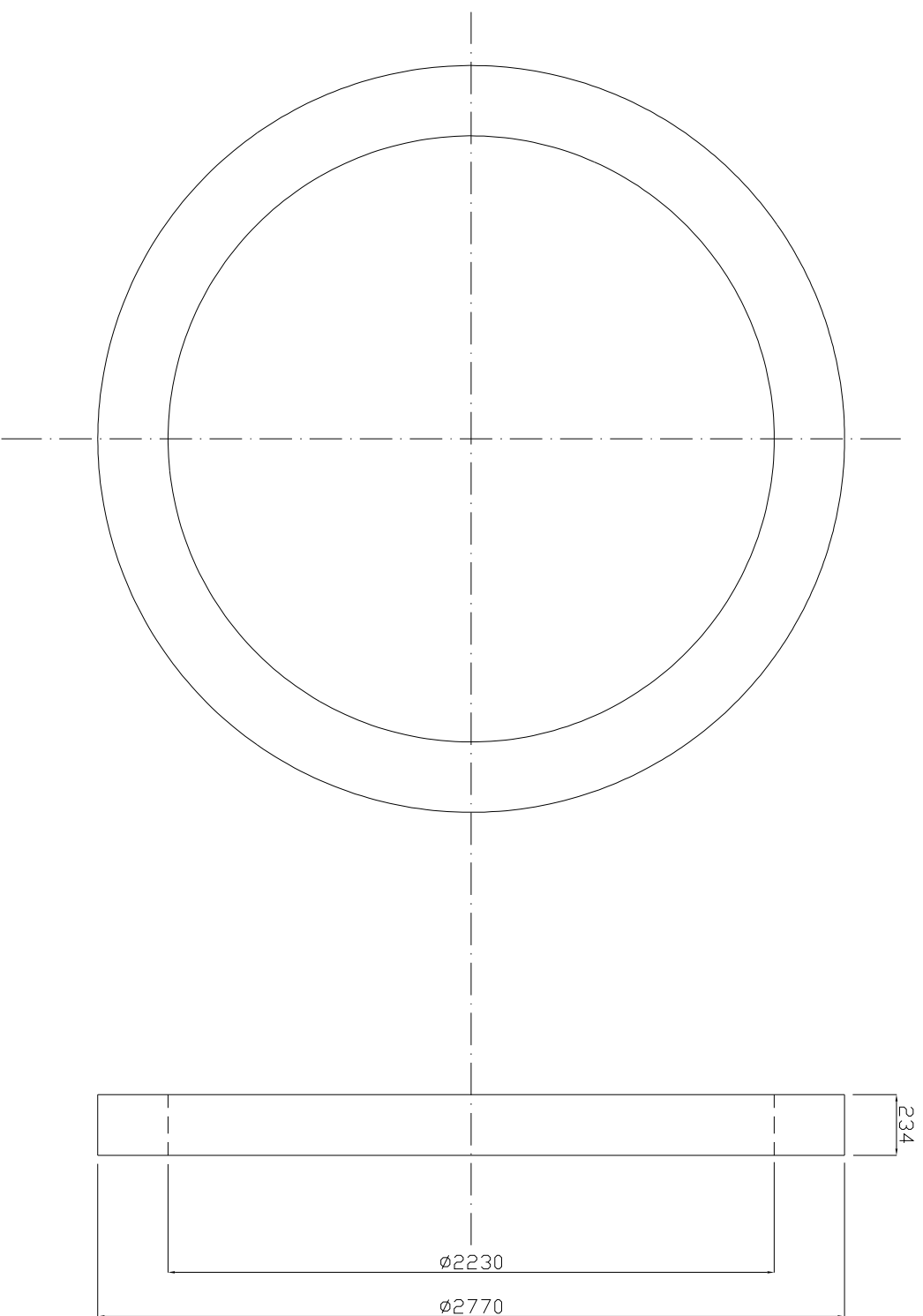

Mjerilo/Scale	Naziv nacrtaj/Drawing title	REVISION	NOV/NB	Klasif. broj/Dwg.No
1:1	RINGS FOR SUBMARINE	0	548	02-201-307
Format		List/Pg	Listova/Pgs	Ident broj/Reg. No
		2	5	332819

# RING FRAME

POS. 212.002-001 5 PCS

MATERIAL: ASTM A350 LF2

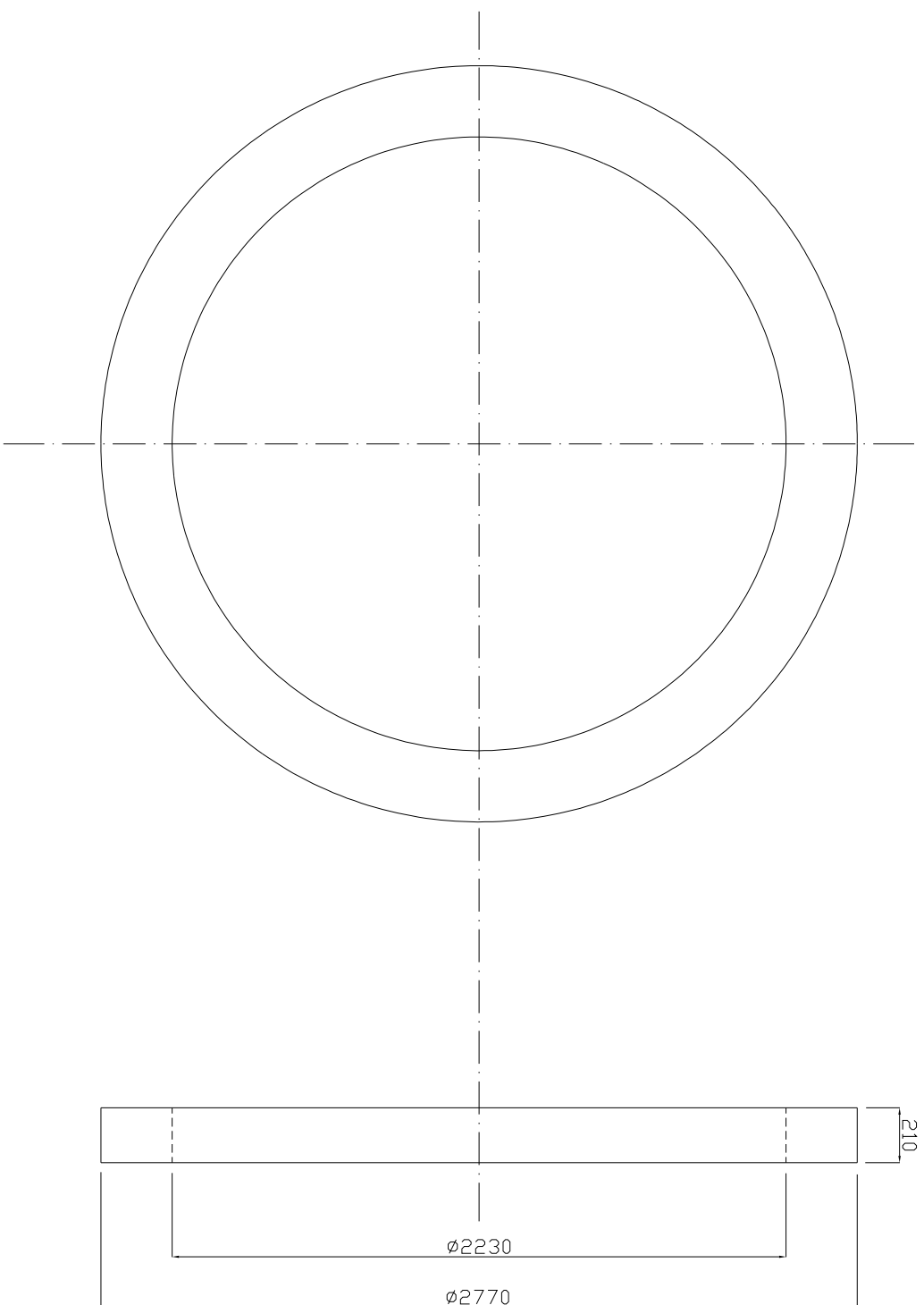

Mjerilo/Scale	Naziv nacrtaj/Drawing title	REVISION	NOV/NB	Klasif. broj/Dwg.No
1:1	RINGS FOR SUBMARINE	0	548	02-201-307
Format		List/Pg	Listova/Pgs	Ident broj/Reg. No
		3	5	332819

# FORE HULL VIEWPORT FLANGE

BIS PROJEKTI NI URED - SPLIT  
DIV GRUPA d.o.o.

POS. 213.001-015 1 PCS

MATERIAL: ASTM A350 LF2

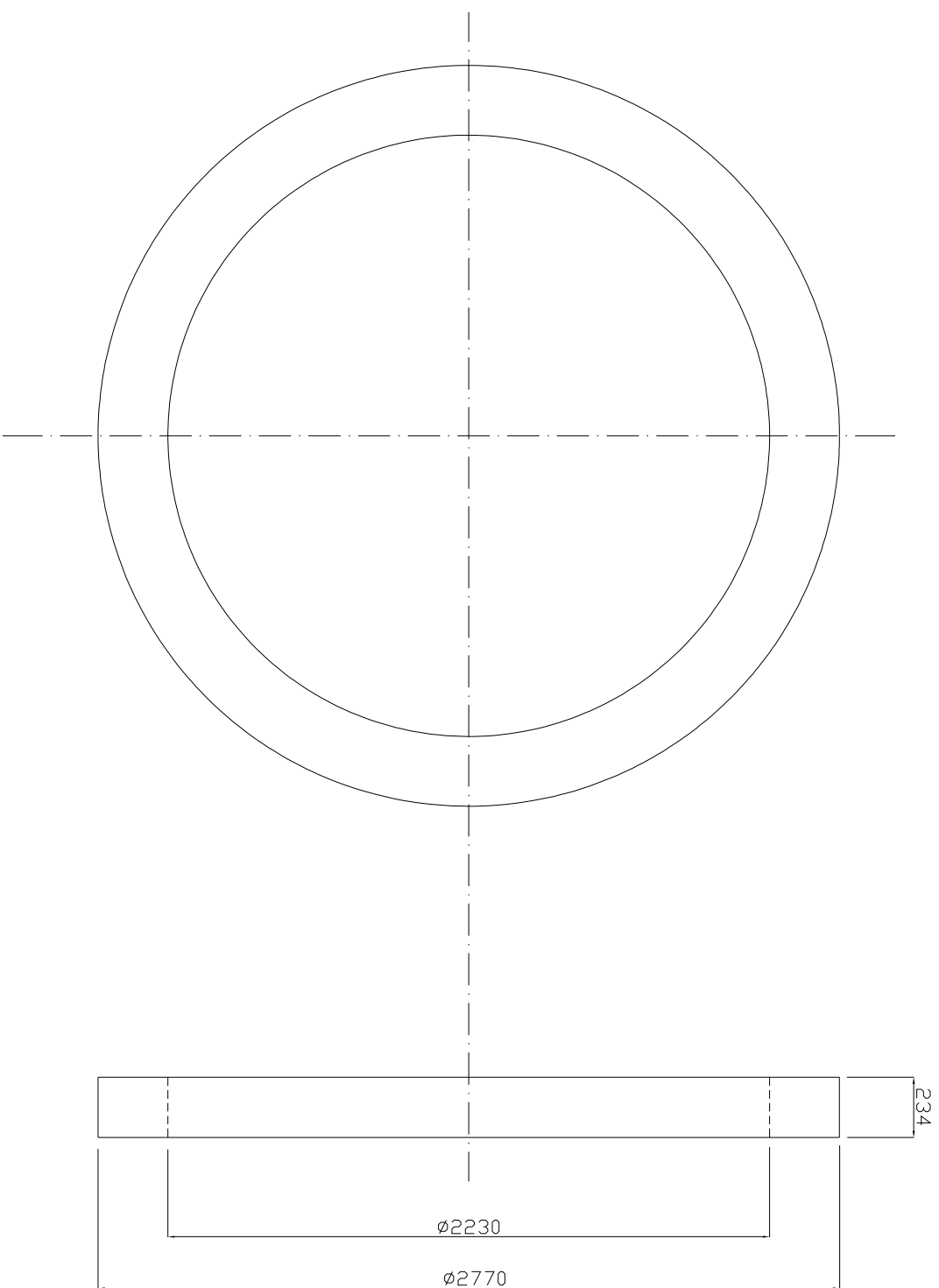

Mjerilo/Scale	Naziv nacrtaj/Drawing title	REVISION	NOV/NB	Klasif. broj/Dwg.No
1:1	RINGS FOR SUBMARINE	0	548	02-201-307
Format		List/Pg	Listova/Pgs	Ident broj/Reg. No
		4	5	332819

# FORE SPHERICAL VIEWPORT FLANGE

BIS PROJEKTI NI URED - SPLIT  
DIV GRUPA d.o.o.

POS. 213.002.002-001 1 PCS

MATERIAL: ASTM A350 LF2

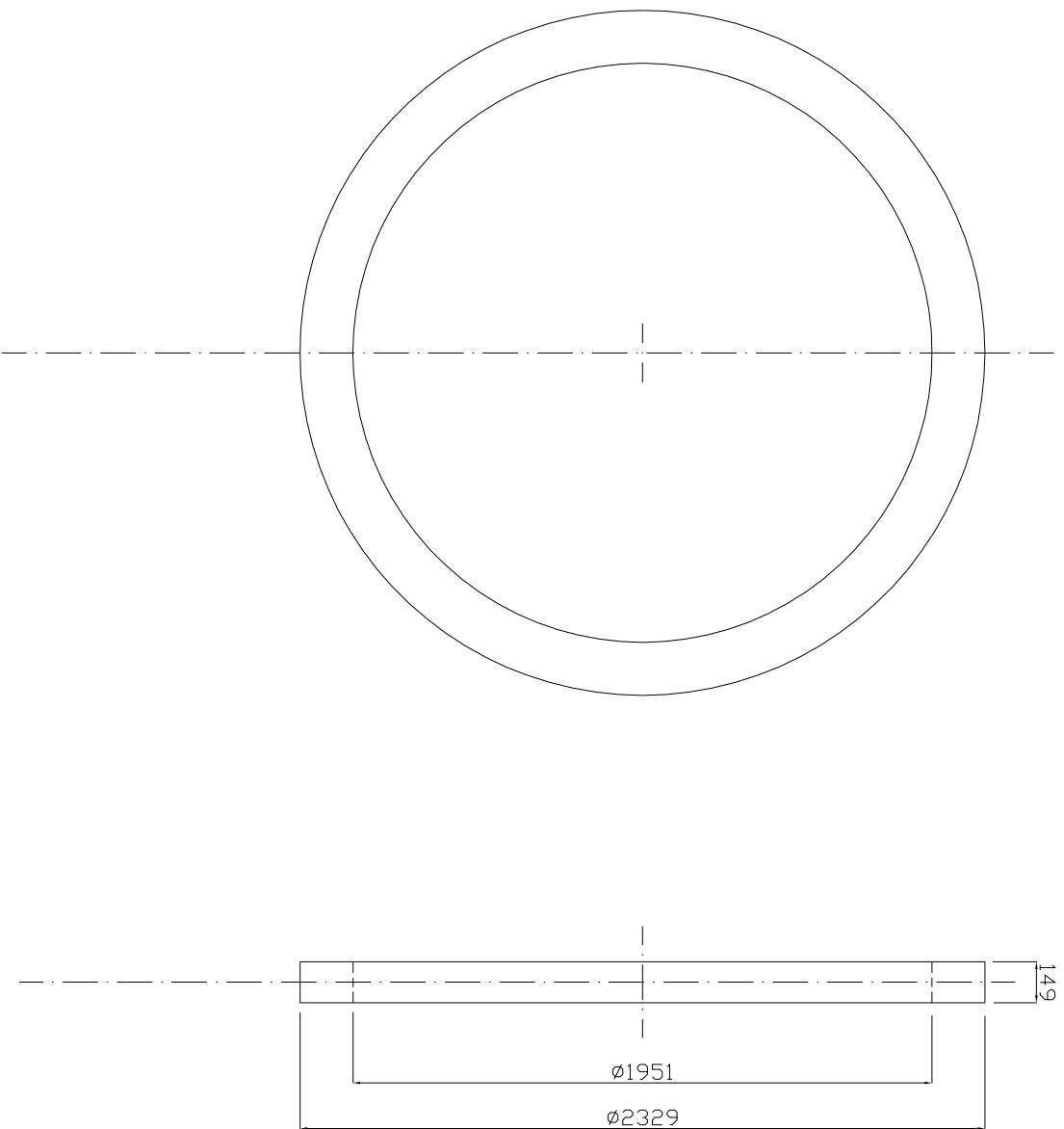

Mjerilo/Scale	Naziv nacrtaj/Drawing title	REVISION	NOV/NB	Klasif. broj/Dwg.No
1:1	RINGS FOR SUBMARINE	0	548	02-201-307
Format		List/Pg	Listova/Pgs	Ident broj/Reg. No
		5	5	332819